

FAMILY OWNED AND OPERATED SINCE 1933



Hannay Reels®
The reel leader.

Ordering & Accessory Guide



The
Hannay
Way

Order hose and cable reels and accessories for:

- Fire and rescue operations
- Welding
- All industrial uses, for production and maintenance
- Aviation
- Sewer and Pipe Cleaning
- LP gas delivery
- Petroleum delivery
- Lubrication
- Lawn maintenance
- Pest control
- Food processing
- Steam cleaning/ Pressure wash
- Off-shore and marine applications
- Custom applications
- Construction/Mining

www.hannay.com

Pride in workmanship • Reels built to order • Consistent quality • Service with integrity • Value for your dollar

CONTENTS

Selecting the Reel..... 1
 Start with the Hose or Cable 1

Part I: Hose and Cable Reel Ordering Guide..... 2

Reel Components 2
 The Anatomy of a Hannay Hose Reel 2
 General Specifications of Hannay Hose Reels 2
 The Anatomy of a Hannay Cable Reel..... 3
 General Specifications of Hannay Cable Reels..... 3

Ordering Options 4
 Hub Assembly Options 4
 Rewind Options 4

How to Specify Hannay Reels 5
 General Ordering Information 5
 Specifying Location of Components..... 6
 Specifying Spring Rewind Reels 7
 Hose and Cable Roller Positions 7
 Hannay Reels Order Worksheet 8

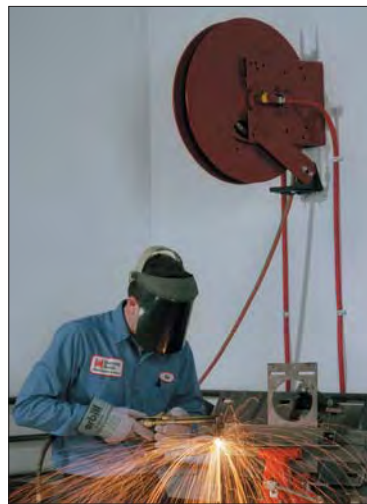

Part II: Accessory Catalog 9

Accessories 9
 Brakes and Locks 9
 EH-820 Bearing/Brake Assembly..... 9
 PL-1 Pin Lock..... 9
 RCB Kits, Switches..... 10
 Speed Controls 10 & 11
 Circuit Breakers..... 11
 Operating Switches for Electric Rewind Reels 11
 Rewind Motors..... 12
 Rewind Assemblies for Gear-Driven
 Crank Rewind Reels 12
 Clutch and Reduction Assemblies 13
 Hose and Cable Stops..... 13
 Hose Assemblies 13
 Roller Assemblies..... 14
 Utility Hose Rollers..... 14
 Hose Guide..... 14
 GM-700 Guidemaster 15
 FH-3 Roller and Spool Assembly 15
 Accessories Order Form..... 16
 Hannay Reels Policies..... 17

Mission Statement

Leadership	To maintain our position as the world leader in hose and cable reels through innovation, production and customer responsiveness.
Value	To deliver value to our customers by providing high quality products on a timely basis at competitive prices.
Development Profitability	To encourage and facilitate employees' professional and personal development. To remain profitable in order to provide a return on investment for our employees, stockholders and suppliers.
Stewardship	To act as a responsible and ethical corporate citizen in our community and in the larger world, investing in charitable causes which will enhance the physical, mental and spiritual well-being of those around us.

SELECTING THE REEL

Start with the Hose or Cable

Start with the hose/cable: the size, length, and type of hose/cable to be handled are primary factors in selecting the proper reel for your job. The following points should be considered:

Be sure to use good quality hose rated for the service and operating pressures required. Poor quality hose tends to expand and contract under pressure surges. When this happens, hose remaining on the reel may bind and become difficult to handle. In extreme cases, poor quality hose may expand under pressure to the extent that the reel becomes distorted and is put out of operation.

It is important to use good quality cable, properly sized, with the correct number of conductors to carry the proper amperage and voltage. Consideration should be made for length of cable versus size of conductors as well as local electrical codes.

We have been manufacturing reels since 1933, and the reels listed in all of our catalogs are those found most in demand to handle hose/cable. Because our reels are assembled from a stock of standard components, we can produce many more sizes than are shown.

If the exact reel you need is not shown in any of the catalogs, please contact us with your specific requirements.

We may be able to produce your reel from standard components, at no extra cost to you.

The drawing shows two reels with identical capacity although the A and G reel dimensions are quite different. In most cases, more than one reel model will handle a particular size and length of hose or cable. Once you determine the size and length of hose or cable you need, you can specify a reel with the dimensions best suited to the available space.

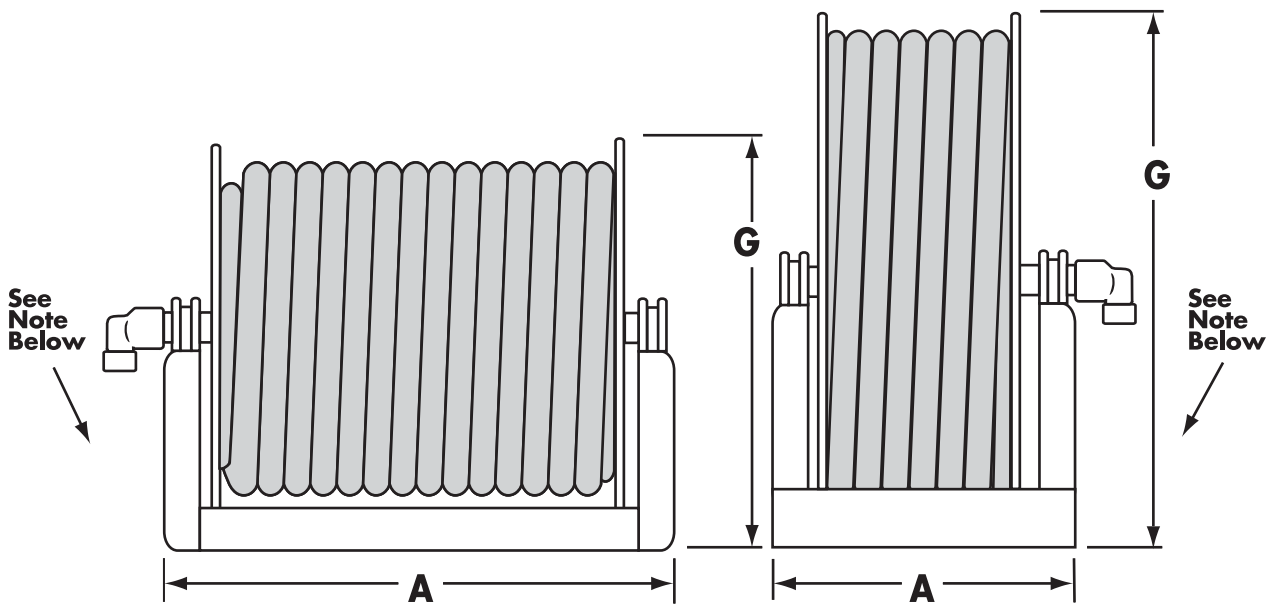

Sample Model Number Configuration			
EF	32-23-24	RT	H5M
Prefix Type of Reel/Rewind*	Model Number Reel Size	Suffix Component Orientation	Pressure Rating (5000 psi) Pressure
* E = Non-Explosion Proof Motor A = Air EPJ = Explosion Proof with Explosion Proof Switch and Junction Box	EP = Explosion Proof Motor HD = Hydraulic	EF = Non-Explosion Proof Motor (Fire) C = Cable Storage	

INSTALLATION NOTE: For the Hannay Warranty to be valid A FLEXIBLE CONNECTOR MUST BE USED BETWEEN THE SWIVEL AND THE INLET PIPING.

The Anatomy of a Hannay Hose Reel

1 Bearings

Weight of spool and hose is supported by bearings.

1a Back bearing

1b Front bearing

2 Disc

Rolled edges prevent hose damage and add rigidity to disc. Additional strength is provided by a concentric rib.

3 Drum

Roll formed steel with full-length weld.

4 Tie rods

Join discs and drum to form spool. Reinforced with pipe spacers for rigidity and strength.

5 Chain and sprocket drive

Provides smooth positive rewinding on powered reels.

6 Rewind motor

Electric rewind motor is shown. Compressed air or hydraulic motors can be used.

6a Electric Junction Box

7 Hub assembly

Includes the fluid hub, the outlet riser and the reel axle. Fluid passes from the swivel joint inlet through the hub assembly, to the hose.

7a Outlet riser

Contoured to match the curve of the reel drum so hose will wrap smoothly.

7b Fluid hub

Permits reel to rotate freely while connected to the fluid source. Joint is not used as a bearing. Straight or 90-degree swivel joints are available for most models. (Flexible connector must be used between swivel joint and inlet piping or warranty will be void.)

9 Brake/Rewind Assembly

Bevel gear rewind has an adjustable tension brake. Rewind and braking devices vary with different models.

10 Front frame

11 Back frame

12 Front foot

13 Back foot

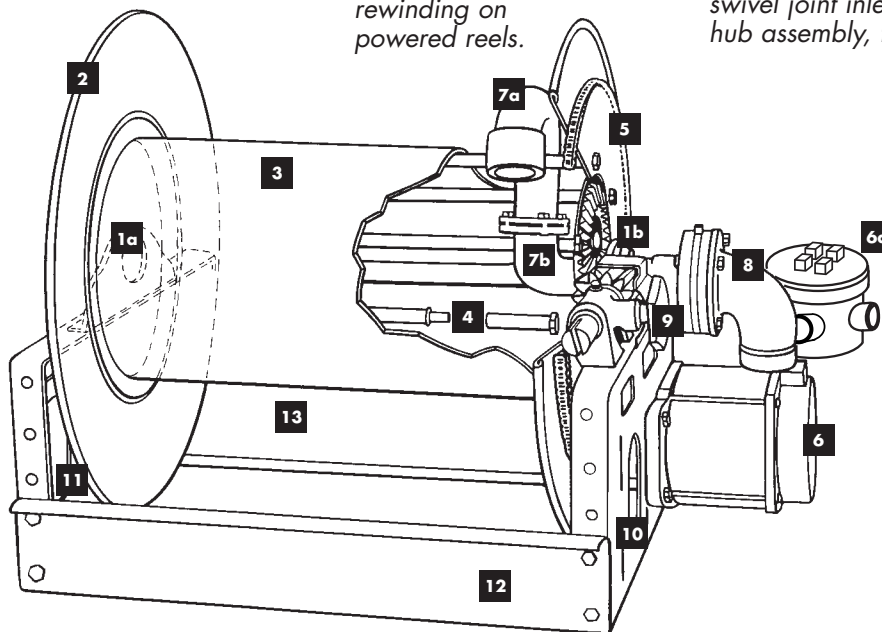

This cutaway illustration shows a typical power rewind reel with an optional auxiliary crank rewind mechanism. All Hannay Reels are assembled from combinations of the basic components shown here. Since components are taken from a large inventory, each reel is assembled to the buyer's particular requirements.

General Specifications of Hannay Hose Reels

Construction:

Frames, discs and drum are fabricated of heavy gauge steel. Bearings are self-aligning. Malleable iron and steel are used for hose reel hub assembly, outlet riser and swivel joints. Stainless steel, aluminum, and special swivel joint packing, can be supplied to meet special requirements.

Finish:

Standard finish is oven-cured enamel. Finishes other than standard, such as special primers may be specified at extra cost.

Temperatures & Pressures:

Standard reel construction will handle most liquids or gases at temperatures ranging from -20 degrees to +400 degrees F (-29 degrees to +204 degrees C). Operating pressures available up to 10,000 psi (695 BAR) depending on the specific reel series. These operating pressures and temperatures are shown on descriptive pages in each product catalog. Reels to operate at pressures and temperatures other than standard are available at extra cost.

Shipping:

Reels are shipped completely assembled, ready to install. Installation instructions are supplied with each reel.

REEL COMPONENTS

The Anatomy of a Hannay Cable Reel

1 Bearings

Weight of spool and cable is supported by bearings.

1a Back bearing

1b Front bearing

2 Disc

Rolled edges prevent cable damage and add rigidity to disc. Additional strength is provided by a concentric rib.

3 Drum

Roll formed steel with full-length weld.

4 Tie rods

Join discs and drum to form spool, reinforced with pipe spacers for rigidity and strength.

5 Chain and sprocket drive

Provides smooth positive rewinding on powered reels.

6 Hub assembly

Provides wiring access to the slip ring assembly and serves as the reel axle.

Cable is connected to the slip ring assembly, passes through hub and exits drum through a grommeted hole.

7 Collector ring

Provides electrical continuity through reel as cable is payed out or retrieved.

8 Collector ring cover

Provides protection from current carried through collector ring assembly as well as keeping out contamination.

9 Wiring junction box

Provides connection of reel to incoming power source.

10 Brake/Rewind Assembly

Bevel gear rewind has an adjustable tension brake. Rewind and brake devices vary with different models.

11 Rewind motor

Electric rewind motor is shown. Compressed air or hydraulic motors can be used.

12 Front frame

13 Back frame

14 Front foot

15 Back foot

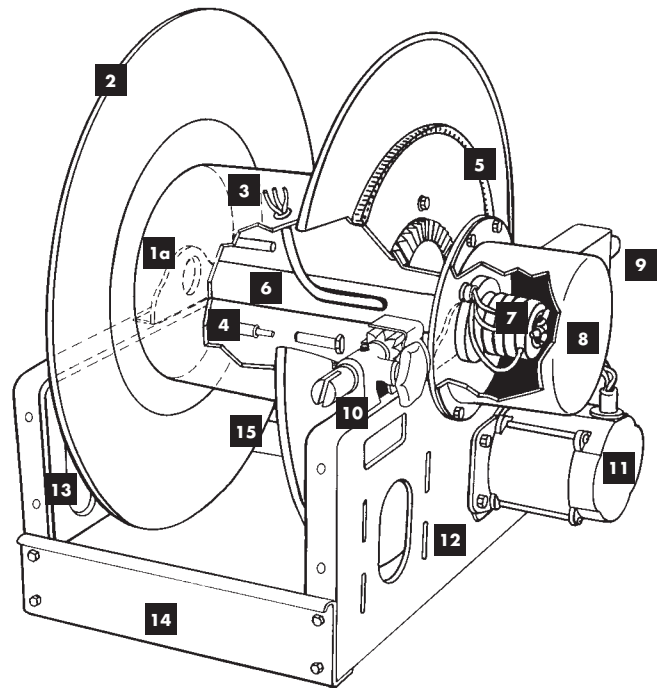

This cutaway illustration shows a typical power rewind reel with an optional auxiliary crank rewind mechanism. All Hannay Reels are assembled from combinations of the basic components shown here. Since components are taken from a large inventory, each reel is assembled to the buyer's particular requirements.

General Specifications of Hannay Cable Reels

Construction:

Frames, discs and drum are fabricated of heavy gauge steel. Bearings are self-aligning. Collector ring housings are ABS plastic or insulated steel, depending on model.

Electrical Connections:

A pull wire is provided for installing cable through drum and hub. Connection from the electrical source to the reel is through a junction box or a preconnected wire lead, depending on the reel model.

Collector Ring Assembly:

Reels to handle live electric cable are normally equipped with a 3-conductor collector ring assembly. Assemblies with additional conductors and for higher amperage are available at extra cost on most models. Be sure to specify your application.

Standard:

45A 600V standard. Up to 300A available at additional cost.

Finish:

Standard finish is oven-cured enamel. Finishes other than our standard, such as special primers may be specified at extra cost.

Shipping:

Reels are shipped completely assembled, ready to install. Installation instructions are supplied with each reel.

ORDERING OPTIONS

Hub Assembly Options

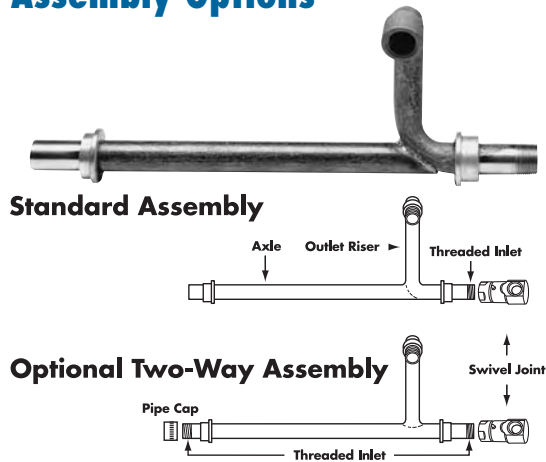

The hub assembly is the heart of the hose reel. It includes the outlet riser, the reel axle and the threaded inlet to which the swivel joint is attached. The swivel joint permits the reel to rotate freely while connected to the fluid source. The outlet riser is engineered to conform to the contour of the drum so the hose lies smoothly against the drum without kinking. Smooth interior surfaces are flow-contoured for unrestricted flow and minimal pressure loss through the reel. A two-way flow hub assembly is available on certain models as an option. On this assembly, the reel axle is threaded on both ends so the swivel joint can be attached at either end to match piping. A pipe cap is supplied to seal the opposite end.

Rewind Options

Manual Rewind Reels

1. Gear-Driven Manual Rewind reels are equipped with a crank operated ring gear mechanism. This mechanism can be used to provide an auxiliary rewind capability on certain power rewind reels (not shown).
2. Disc rewind reels are rewound by manually turning the reel discs.
3. Direct Manual Rewind reels are equipped with either a permanently attached or removable crank (depending on model) which attaches to the reel axle to rewind the reel (not shown).

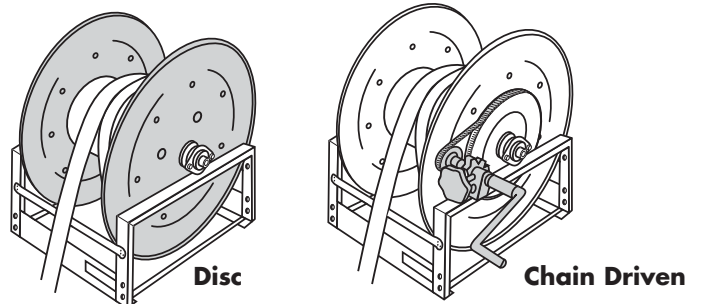

4. Chain-Driven Manual Rewind reels are equipped with a crank operated chain and sprocket mechanism parallel to the reel axle.

Spring Rewind Reels

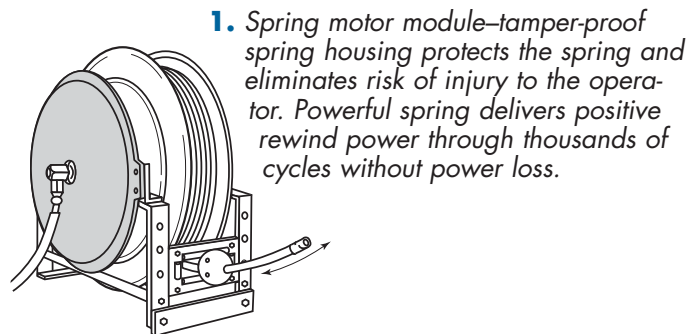

1. Spring motor module—tamper-proof spring housing protects the spring and eliminates risk of injury to the operator. Powerful spring delivers positive rewind power through thousands of cycles without power loss.

2. Ratchet assembly—locks the reel at any point when hose/cable payout stops. A pull on the hose/cable disengages the lock for instant rewinding. This assembly is deleted for automatic payout and rewind for constant tension applications.
3. Declutching arbor—disengages the spring to prevent damage from reverse winding.

Because they utilize self-contained rewind power, spring rewind reels are extremely versatile. No power connections are required and the reels can be installed in virtually any position and on all types of equipment.

Power Rewind Reels

A chain and sprocket mechanism is used on reels with power rewind; the chain drive assures smooth, positive power transmission and minimum maintenance. A choice of electric, compressed air or hydraulic motors is offered for power rewind reels. Specific information on motors and operating controls are listed on pages 11 and 12.



Air Rewind with Control Valve Shown

HOW TO SPECIFY HANNAY REELS

General Ordering Information

A precise and complete purchase order is your best assurance of prompt delivery of the exact reel you need. Your order should include all information listed. It is better to overspecify than to omit important information. When space permits, select a reel with greater capacity

than you actually need. This allows you to rewind the hose/cable with less care and keeps the hose/cable well protected within the disc dimension even if it is not wound in uniform coils. In most cases, the larger reel, in the same series, costs no more.

Continuous-Flow Hose Reels

Orders for all continuous-flow hose reels should specify:

- Complete model number
- Type of rewind
- Length, ID and OD of hose(s)
- Maximum working pressures
- Size and thread of outlets
- Minimum bend radius
- 90-degree (standard) or straight swivel joint
- Liquid, gas or other product to be handled
- Oxygen/acetylene use
- Product temperature range
- Finish, if other than standard
- How reel will be installed and used
- Accessory items required

Live Electric Cable Reels

Orders for live electric cable reels should specify:

- Complete model number
- Type of rewind
- Gauge, length, OD and weight of cable
- Cable voltage and amperage
- Minimum bend radius
- Number of conductors required
- Finish, if other than standard
- How reel will be installed and used
- Accessory items required

Dry-Storage Reels

Orders for dry-storage reels should specify:

- Complete model number
- Length, OD and weight of hose, cable, rope or other material to be handled
- Bending radius, if material is not easily coiled
- Type of rewind
- Divider disc spacing, if required
- Finish, if other than standard
- How reel will be installed and used
- Accessory items required

Power Rewind Reels

Orders for power rewind reels must also specify:

- Voltage and phase for electric motor
- Air or hydraulic rewind
- With or without auxiliary crank rewind

Spring Rewind Reels

Orders for spring rewind reels must also specify:

- Roller position, SR, VR or TR
- Hose stop, if required [specify OD of hose(s) or cable(s)]
- Ratchet locking (standard) or without ratchet for automatic operation
- Height of lift, if reel is to lift hose/cable & weight
- Describe installation in terms of lift, stretch, drag or recovery (see page 8)

INSTALLATION NOTE: For the Hannay Warranty to be valid (1) A FLEXIBLE CONNECTOR MUST BE USED BETWEEN THE SWIVEL AND THE INLET PIPING, (see illustration on page 1 of this catalog), and (2) on DC electric rewind reels, a circuit breaker must be installed between the battery and the rewind motor.

HOW TO SPECIFY HANNAY REELS

Specifying Location of Components

Optional Location of Components:

Location of the inlet, outlet riser and rewind mechanism can be varied to meet your requirements and **must be specified on your order**. The drawings below show

the component locations. Unless otherwise specified, most reels will be shipped as **Right Top Rewind** with the inlet, outlet riser and rewind mechanism on the operator's right.

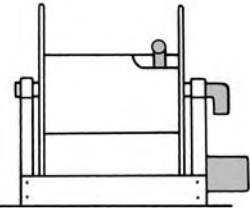

Right Top Rewind (RT) reels have the inlet, outlet riser and rewind mechanism on the operator's right. Hose unwinds from the top of the reel.

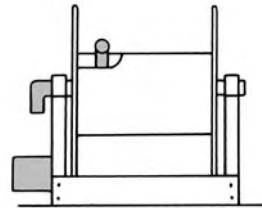

Left Top Rewind (LT) reels have the inlet, outlet riser and rewind mechanism on the operator's left. Hose unwinds from the top of the reel.

Standard – Always look at your reel from this position to determine right hand or left

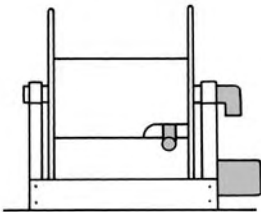

Right Bottom Rewind (RB) reels have the inlet, outlet riser and rewind mechanism on the operator's right. Hose unwinds from the bottom of the reel.

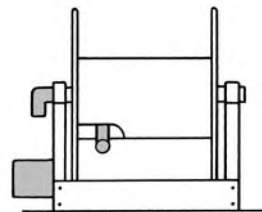

Left Bottom Rewind (LB) reels have the inlet, outlet riser and rewind mechanism on the operator's left. Hose unwinds from the bottom of the reel.

Note: Use position initials as suffix after model number, ie: EF32-23-24-RT

Optional Motor Locations

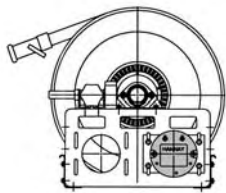

Bottom Rear (Standard)

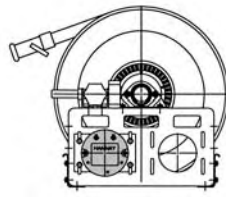

Bottom Front

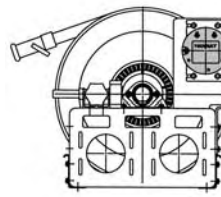

Elevated 2 o'clock

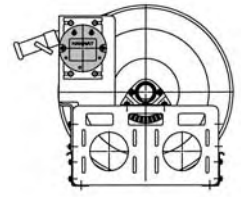

Elevated 10 o'clock

Electric rewind motors can be installed in any of the positions shown in these drawings. The **Bottom Rear** position is standard. The motor is installed inside the frame

on Model ESF reels (see Firefighting catalog page 6), which are designed for installation in restricted space.

Optional Auxiliary Rewind Positions

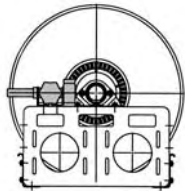

Horizontal (Standard)

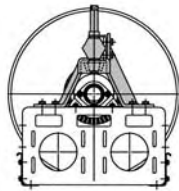

Vertical

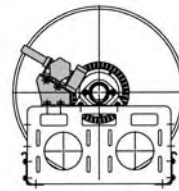

30° Angle

Horizontal ring and pinion gear crank rewind mechanism is the standard configuration. Optional positions include vertical and 30° above centerline, as shown in these

drawings. Both are available at extra cost and **must be specified**.

HOW TO SPECIFY HANNAY REELS

Specifying Spring Rewind Reels

Important installation guide.

For proper reel operation, rewind springs must be precisely matched to the job. Your order should include a detailed description of how the reel will be installed and used. This will also help to determine the best roller position.

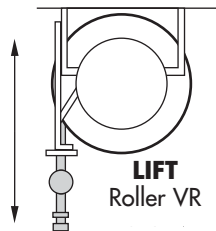

Vertical Lift-

Reel is installed overhead, on wall or ceiling, to lift hose/cable and product being handled. Spring must have power to lift total weight of hose/cable **plus any weight which will be attached to the hose/cable** such as a power tool. Reel can be

manually operated or pay out and rewind **automatically**. Specify height of lift and weight of hose/cable and attachments when you order.

Drag-

Reel is stationary and retracts hose/cable across floor or other surface. Spring must have power to compensate for friction. Reel can be manually operated or pay out and rewind **automatically**.

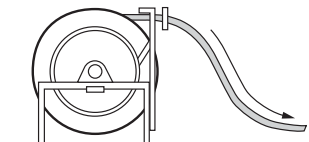

DRAG
Roller TR

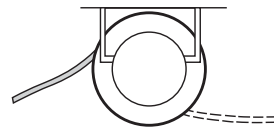

STRETCH
Two-way payout
No Roller

Stretch-

Reel is stationary and retracts suspended hose/cable attached to moving equipment. Reel pays out and rewinds **automatically**. Spring must have power to compensate for weight of unsupported hose/cable. Specify maximum hose sag allowable.

Recovery-

Reel is installed on moving equipment or at a fixed center point to retract and pay out hose/cable in two directions. Reel pays out and rewinds **automatically**. If reel travels, specify speed of travel, acceleration rate, and height of reel above recovery surface.

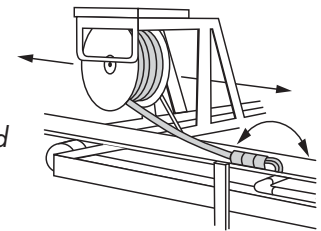

RECOVERY (Pick up)
No Roller

Note: A rough drawing of your specific installation plans will be extremely helpful.

Hose and Cable Roller Positions

On standard spring rewind reels, the hose/cable pays out from the bottom of the reel and to the left when reel is viewed from the swivel joint or collector ring side.

Hose/cable rollers are supplied with all spring rewind models and you must specify the roller position when you order. (If roller position is not specified, reels will be shipped with rollers in POSITION SR.)

Pricing Note: When reels are ordered for constant tension applications, the ratchet assembly and in some cases hose rollers are not required. See price list for deductions.

Specify roller position SR when:

- Reel will be installed in the upright position at any point from floor to eye level.
- Reel will be installed on a wall with hose/cable to be retracted close to the wall.
- Reel will be installed on ceiling and hose/cable will pay out parallel to and close to the ceiling.

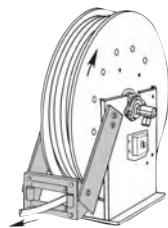

POSITION SR
(is Standard)
Swivel Joint Right

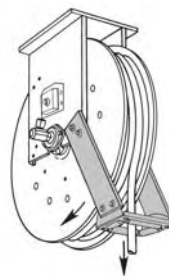

POSITION VR
Swivel
Joint Right

Specify roller position VR when:

- Reel will be installed in the upright position and hose/cable will be pulled upright from the reel.
- Reel will be installed on ceiling to lift hose/cable.
- Reel will be installed on a wall with hose/cable to be pulled straight out.

Specify roller position TR when:

- Reel will be installed on floor.
- Reel will be installed on ceiling with hose/cable to pay out parallel to the ceiling.

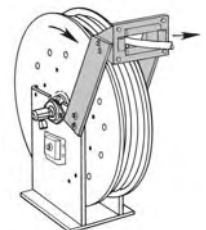

POSITION TR
Swivel joint Left

BE SURE TO SPECIFY ROLLER POSITION WHEN ORDERING.

Arrows show direction of reel rotation and direction in which hose/cable unwinds.

HOW TO ORDER REELS

Hannay Reels Order Worksheet

To order Hannay Reels, fill out this simple form (or a photocopy) and mail or fax to your Hannay Reels dealer.

1. Who's the reel for?

Company _____	Street Address _____			
Division _____	City _____	State _____	Zip _____	Country _____
Contact _____	(_____) _____	Telephone _____	Fax _____	Date ____/____/____

2. What is the reel for?

HOSE (check one):

Live Storage only Single hose Dual hose

Inside diameter: _____

Outside diameter: _____

Bend radius: _____

Hose length: _____

Hose weight: _____

Flat hose dimensions: _____

Coupling spacing: _____

Type of product handled live application (check one):

Liquid (specify type): _____

Gases (specify type): _____

Oxygen/Acetylene: _____

Other (specify type): _____

Hydraulic fluid (specify type): _____

Temperature: _____

Pressure: _____

CABLE (check one):

Live Storage only

No. of conductors required: _____

Outside diameter: _____

Bend radius: _____

Reel inlet type (check one):

90° Straight

Special material (internal hub assembly)

Aluminum Malleable iron Stainless steel Steel

Connector size: _____

Reel outlet type (riser):

Size: _____

Thread (check one):

National Pipe Thread (NPT)

Joint Industry Committee (JIC)

National Standard Thread (NST)

British Standard Pipe (BSP)

Other

Indicate your custom specifications _____

Cable length: _____

Number of Connectors: _____

Cable weight: _____

Amperage (live application only): _____

Voltage: _____

3. What features does the reel need?

Check type of rewind:

MANUAL

Disc rewind (hand over hand) Gear-drive crank

Direct crank (permanent or removable) Chain-drive crank

POWER

Spring Electric (voltage: _____)

Air Hydraulic

Check type of installation:

Floor Wall Overhead Vehicle

Temperature Range: _____

Environment: _____

Accessories (if any): _____

Finish (if other than standard): _____

Roller Assemblies: _____

Hose/Cable Stop: Yes No Specify Hose/Cable O.D. _____

Check type of installation and roller position for spring reels:

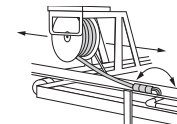
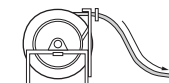
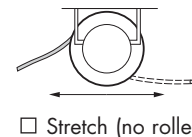
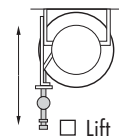

Roller

Position VR
 Position TR

Position SR
 Constant tension

4. Please note size and/or weight limitations for your installation

Length _____ Width _____

Height _____ Weight _____

For custom applications not found in our catalogs, call the Inside Sales Group at (518) 797-3791.

Brakes and Locks

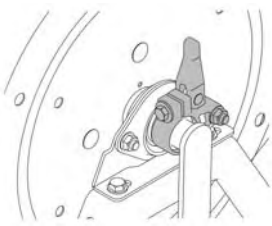

Cam-Lock Drag Brake

Molded plastic drag brake with cam lock lever designed for 1/2" and 1" manual reels. Corrosion proof and does not harm the hub. Infinitely adjustable for the desired drag tension to prevent cable or hose overrun. Instantly releases with the flip of a lever for drag free rewind.

To order, specify part number (see Price List H-0415-OAL).

For factory installation, specify Cam-Lock Drag Brake with reel order.

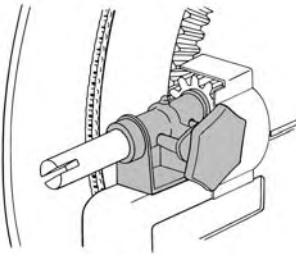

Pinion Brake

Adjustable spring tension applies braking pressure to pinion shaft on reels equipped with ring gear rewind mechanism.

To order, specify part number (see Price List H-0415-OAL).

For factory installation, specify Pinion Brake with reel order.



Comet Brake

Adjustable steel strap lined with brake pad material applies drag pressure to reel axle to control payout speed of the reel.

To order, specify part number (see Price List H-0415-OAL).

For factory installation, specify Comet Brake with reel order.

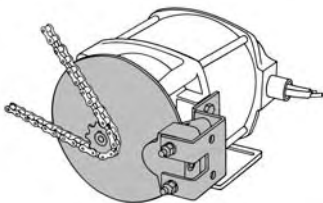

Caliper Brake

Clamps a disc on the motor shaft for positive locking of reels with power rewind. Can be operated manually, hydraulically or by compressed air.

To order, specify part number (see Price List H-0415-OAL).

For factory installation, specify Caliper Brake with reel order.

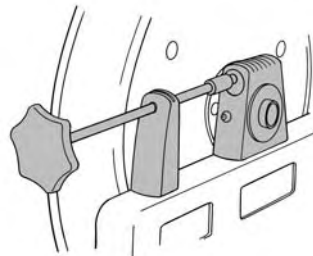

EH-820 Bearing/Brake Assembly

This assembly provides an alternate method of braking control on certain model reels. Assembly is installed in the back bearing position. Brake applies pressure to the reel axle to slow or lock the reel.

Can be factory installed, when specified with reel order, or supplied in kit form for field installation.

To order, specify part number (see Price List H-0415-OAL.)

For factory installation, specify Bearing Brake/Assembly with reel order.

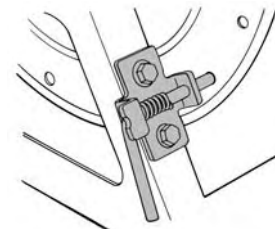

PL-1 Pin Lock

A positive, spring-actuated pin lock to prevent free-wheeling or recoil from pressure surges. May be factory-installed when specified on your reel order.

To order, specify part number (see Price List H-0415-OAL).

For factory installation, specify Pin Lock with reel order.

ACCESSORIES

"RCB" Kits (12V DC)

Reel-Mounted Relay & Circuit Breaker

Factory-installed, eliminating need to fabricate and mount a circuit breaker and solenoid/relay.



Model RCB-25

- **RCB-25** designed for 1/5 HP, 12V DC reels (ECR1600, EF2000, and EF1500 series).
- **RCB-40** designed for 1/3 HP, 12V DC reels (E1500, E1800, E4000, EF4000)

"SRCB" Switches (12V DC)

Panel-Mounted Switch, Relay & Circuit Breaker

Integrated push-button rewind switch, relay, and circuit breaker, all mounted behind an attractive brushed aluminum panel. Eliminates need to separately mount and wire individual electrical components.



- **SRCB-25** designed for 1/5 HP reels
- **SRCB-40** designed for 1/3 HP reels

Model SRCB-25

"SB" Switches (All Voltages)

Enclosed Reversing Switch, Relay & Circuit Breaker

Integrated push-button REVERSING rewind/unwind switch, relay, and circuit breaker, all mounted in a weather resistant enclosure with mounting studs. Eliminates need to separately mount and wire individual electrical components.



Model SB-1250SR

- **SB-1250SR** designed for 1/2 HP 12V DC reels
- **SB-2425SR** designed for 1/2 HP 24V DC reels
- **SB-115SR** designed for 1/2 HP 115V AC reels

"SR" Speed Controls (All Voltages)

Enclosed Fixed Speed Control

Offers a fixed (50%) reduction in motor speed at an economical cost. Mounted in a weather-proof enclosure. Works with all Hannay motors and does not significantly affect motor torque.



Model SR-115

- **SR-115** designed for Hannay AC motors

"MD" Speed Controls (All Voltages)

Enclosed Variable Speed Control

Offers a fully adjustable reduction in motor speed with a variable speed control knob. Mounted in a weather-proof enclosure. Works with all Hannay motors and does not significantly affect motor torque.

- **MD-70** designed for Hannay DC motors
- **MD-115** designed for Hannay 115/230V AC motors



Model MD-70



Model MD-115

"MD" Switch/Speed Controls(All Voltages)

Enclosed Switch, Relay Circuit Breaker & Variable Speed Control

Integrated push-button rewind switch, variable speed control, relay and circuit breaker, all mounted in a weather resistant enclosure with mounting studs.

- **MD-1225S** designed for 1/5 HP, 12V DC reels
- **MD-1240S** designed for 1/3 HP, 12V DC reels
- **MD-12HDS** designed for 1/2 HP, 12V DC reels
- **MD-115S** designed for Hannay 115/230V AC reels
- **24V DC** models also available



Model MD-1225S



Model MD-115S

"MD" Reversing Switch/Speed Controls (All Voltages)

Enclosed Reversing Switch, Relay Circuit Breaker & Variable Speed Control

Integrated reversing push-button rewind switch, variable speed control, relay and circuit breaker, all mounted in a weather resistant enclosure with mounting studs.

- **MD-12HDSR** designed for all 12V DC reels
- **MD-115HDSR** designed for Hannay 115/230V AC reels
- **24V DC** model also available



Model MD-12HDSR



Model MD-115HDSR

Circuit Breakers

Must be used with all DC electric rewind motors.

SDLM Manual Reset. Push-button must be pressed firmly to reset. Several amperage ratings are available to suit specific application.

CB-2 Mounting bracket for SDLM Breaker.



SDLM Circuit Breaker



CB-2 Bracket



25 Amp Circuit Breaker

To Order: Specify SDLM and give Model Number of reel motor. Specify CB-2 bracket, if required.

Operating Switches for Electric Rewind Reels



90030

90030 sealed push-button momentary contact switch with rubber cap for 12 or 24 volt **DC** service.



P15A-00130

P15A-00130 Universal mounting bracket for EPS-1 switch.



EPS-1

EPS-1 explosion-proof cable momentary contact switch for remote control or for permanent mounting in the most convenient location. Supplied with 6 ft. of 3-wire cable, self-sealing fitting and terminals. Must be used with solenoid. (12 volt only)



P15A-00170

P15A-00170 Mounting bracket for use with Guidemaster.



PB-1

PB-1 switch non-explosion-proof, 115v momentary contact switch.



EXPB-2A
EXPBC-2B

EXPB-2A explosion-proof, push-button momentary contact switch for **DC** service only. Must be used with solenoid.

EXPBC-2B For use with **AC** motors.

To Order: Specify Part Number.

ACCESSORIES

Rewind Motors

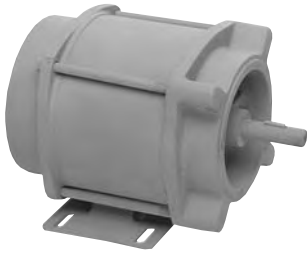

Base mount E.P. Electric Motor



Face mount E.P. Electric Motor



Face mount Non-E.P. DC Motor
(Shown with optional mounting plate part no. 9923.0008)

Hydraulic Motors are reversible type. No other hydraulic components are furnished with the reel. A 4-way, three position control valve with motor spool is recommended but is **not** supplied.



Compressed Air Motors are supplied with a fingertip control valve with integral backpressure relief, and with flexible air line from control valve to rewind motor. We recommend using a lubricator and filter with air rewind motors, not supplied.



Electric Motors are reversible type for AC or DC operation. **Circuit breaker must be used with all DC electric motors.**

Note: All accessories for the above motors are available, but must be ordered separately.

Note: Standard motor voltages available. 12v and 24v DC, 115v AC, 230v AC single phase and 3-phase motors available on special order.

Rewind Assemblies for Gear-Driven Crank Rewind Reels

These assemblies are used to change the pinion shaft position on gear-drive crank rewind reels to meet space restrictions or for greater operator convenience. Units can be factory-installed, when specified with reel order, or supplied in kit form for field installation.

Assemblies are complete with drag-brake assembly, pinion, gear guard, brake handle and fasteners. Fits standard mounting holes on reel frame.

To Order: Specify Rewind Position for parts order or factory installation.



Horizontal rewind unit



30° rewind unit



Vertical rewind unit

Clutch and Reduction Assemblies



Manual Clutch and Reduction Unit

Hannay reduction units are used to increase the torque (by 50 to 500 percent, depending on the ratio chosen) and decrease the rewind speed on power-driven reels. The clutch allows the motor and reduction unit to be disengaged from the reel, eliminating drag in the unwinding mode. The manual clutch is disengaged by means of a user-operated pull rod. The electric clutch requires no user intervention. It automatically engages when the motor is running, and disengages when the motor stops.

Hannay reduction units and clutches are available as a kit for field installations or can be factory-installed when specified with the reel order.



Electric Clutch and Reduction Unit

Reduction unit kits include reduction unit, length of chain, connector links, and fasteners. Clutch/reduction kits include the clutch & reduction unit, length of chain, connector links, and fasteners.

YOU MUST SPECIFY MODEL OF REEL THE ASSEMBLY IS TO BE INSTALLED ON.

Available ratios.

REDUCTION UNIT ONLY	CLUTCH & REDUCTION UNIT
12/18	12/40
12/25	12/48
12/36	12/60
12/48	
12/60	

Hose and Cable Stops

Recommended with spring rewind reels and 4-way roller assemblies

- All stops are quickly installed with included plated fasteners.
 - The HS-35 is our standard stop, used for most applications up to and including 1" ID hose.
 - HS-35 two-piece stops are molded from EPDM rubber for durability and maximum grip.
 - HS-3 and HS-45 two-piece stops are molded from polypropylene, and are custom drilled to the size you specify.
- To order, use Hannay part number from chart below (specify single or twin hose). Specify the outside diameter (OD) of your hose or cable. Please note that for the plastic stops, the drilled hole size will be 1/16" (single hose) or 1/32" (twin hose) smaller than the OD of the hose you specify to ensure a good grip.

Part No.	Spherical OD	Min Hose or Cable OD	Max Hose or Cable OD	Material	Best Used
HS-35	3.5"	0.44"	1.53"	EPDM Rubber	1/4" thru 1" ID Hose; Most multi-gauge Cable
HS-35-Twin	3.5"	0.47"	0.91"	EPDM Rubber	1/4" thru 1/2" Twin ID Hose
HS-45	4.5"	None (drilled)	2.69"	Plastic	1-1/4" thru 2" Hose
HS-45-Twin	4.5"	None (drilled)	1.28"	Plastic	3/4" Twin ID Hose
HS-3	3.0"	None (drilled)	1.81"	Plastic	Hose/Cable OD less than 0.44"
HS-3-Twin	3.0"	None (drilled)	0.91"	Plastic	Twin Hose OD less than 0.47"

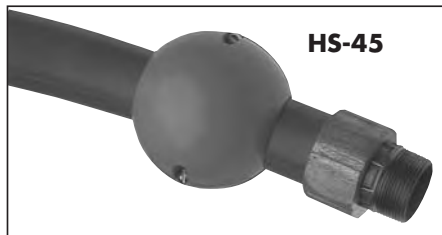

HS-45

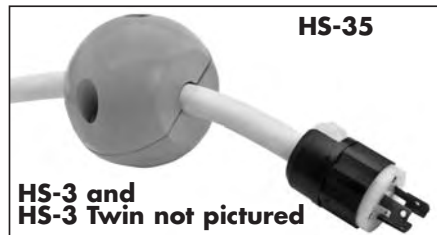

HS-35

HS-3 and HS-3 Twin not pictured

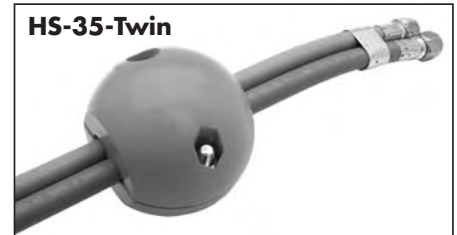

HS-35-Twin

Hose Assemblies

Various Hose Assemblies available for a wide variety of applications. See form H-0308-H.

ACCESSORIES

Roller Assemblies for Spring Rewind Reels



N200



R200



R300



EH-714



PW-2R Roller

These 4-way roller assemblies are for use on the reel, on cabinet door openings and for similar locations where sharp metal edges may cut or damage the hose/cable. 4-way design protects hose even when payout or rewind is at an angle.

The N200 and R200 roller assemblies have Delrin rollers mounted in stamped steel housings for flush panel mounting, reel mounting (R200) or right angle mounting (N200).

The R300 roller assemblies have stainless steel rollers, Delrin bearing inserts and zinc die-cast corner mounting blocks assembled on a steel mounting frame.

To Order: Specify Part Numbers N Models for N Series Reels, R Models for Channel Frame Reels

Note: A hose stop should be used with 4-way rollers to prevent damage to rollers and nozzles. See description on page 13.

PART NO.	OVERALL DIMENSIONS		ROLLER OPENING	
	INCHES	MM	INCHES	MM
R203	8.0 x 5.5	203.2 x 139.7	2.5 x 2.0	63.5 x 50.8
R204	9.0 x 5.5	228.6 x 139.7	3.5 x 2.0	88.9 x 50.8
R205	10.0 x 5.5	254.0 x 139.7	4.5 x 2.0	114.3 x 50.8
R206	11.0 x 5.5	279.4 x 139.7	5.5 x 2.0	139.7 x 50.8
N203	5.5 x 5.5	139.7 x 139.7	2.5 x 2.0	63.5 x 50.8
N204	6.5 x 5.5	165.1 x 139.7	3.5 x 2.0	88.9 x 50.8
N205	7.5 x 5.5	190.5 x 139.7	4.5 x 2.0	114.3 x 50.8
N206	8.5 x 5.5	215.9 x 139.7	5.5 x 2.0	139.7 x 50.8
R306	11.25 x 7.0	285.8 x 177.8	5.5 x 2.38	139.7 x 60.45
R308	13.25 x 7.0	336.6 x 177.8	7.5 x 2.38	190.5 x 60.45
R310	15.25 x 7.0	387.4 x 177.8	9.5 x 2.38	241.3 x 60.45
PW-2R	9.75 x 3.75	247.7 x 95.3	5.13 x 1.13	130.3 x 28.7
EH-714	9 x 5.625	228.6 x 142.9	2.5 x 2.5	63.5 x 63.5

Utility Hose Rollers

Stainless steel rollers and cast alloy brackets for use on the reel, on cabinet door openings, truck platforms and similar locations where sharp edges may cut or damage hose/cable.

Specifications: 1-1/2" diameter stainless steel roller, stainless steel rod, Delrin bearings, alloy brackets and required fasteners.

To Order: Specify Assembly A, B, or C, and give distance between **each pair** of mounting holes (Dimensions X and Y) and length of each roller (Dimensions W and Z). W=Vert. Roller Length, Z=Horiz. Roller Length.

Also available factory-installed on the reel.

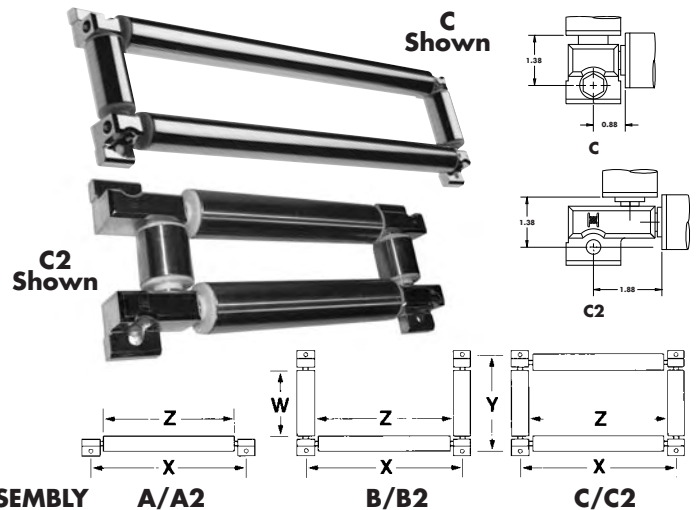

HG-15 Hose Guide for Small Frame Models

An affordable Hose Guide for our 1500-1600-1800-2000-4000 series reels.

- Simple design to rewind hose evenly and neatly every time.
- No need to handle dirty or contaminated hose.
- Powder-Coated bracket, stainless steel guide rods and nylon rollers assure long service life.
- Designed for aftermarket installation.

Hose Guide Kit - HGK-15 Hannay Part #9956.2200

Kit includes HG-15 Hose Guide, handle grip, 2 stainless steel guide rods, 4 mounting blocks, steel mounting bracket set, and all mounting hardware.

Hose Guide - HG-15 Hannay Part #9956.2000

Assembled black powder-coated Hose Guide and handle grip.

You must specify reel model when ordering.



1500 Series shown



view from back of HG-15

GM-700 Guidemaster

Multiposition hose guide with explosion-proof rewind control.

Both models help unwind and rewind hose faster, easier and with less damage to the hose. Five positive locking positions let the operator pull the hose out and away from sharp corners of cabinet or deck. An explosion-proof push-button switch in the Guidemaster handle lets the operator control the rewind motor as he guides the hose on the reel in neat, uniform coils.

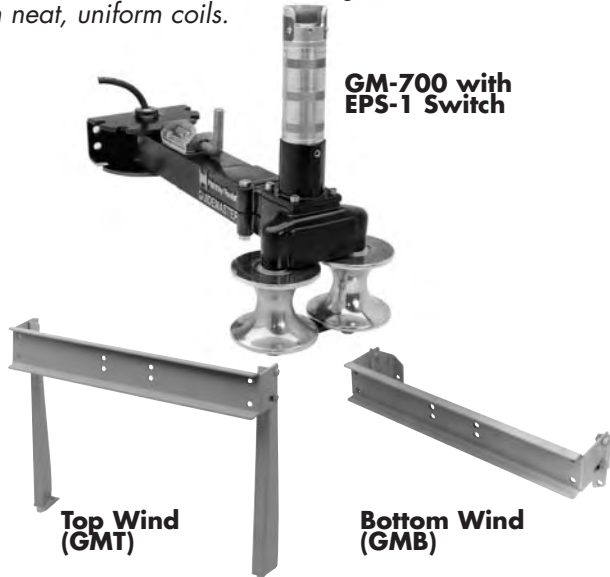

Construction: Cast aluminum alloy housing, stamped steel pivot plate. Polished aluminum alloy rollers turn on ball bearings. Stainless steel spring, components and fasteners are used in the pivot release mechanism. Six feet of wire is supplied to connect operating switch to the solenoid. Switch has Class 1 (Groups A B C D) and NEMA 4X ratings.

The Guidemaster can be ordered in three ways.

1. Guidemaster only, supplied with four mounting bolts and ready to be attached to your mounting brackets.
2. Guidemaster and brackets, includes steel mounting bracket, beveled spacers and fasteners designed for your reel. Ready to install. Specify top or bottom wind.
3. Guidemaster mounting brackets factory installed. Specify top or bottom wind.

To Order: For factory installation of mounting bracket, Guidemaster should be ordered when you order the reel. When purchasing Guidemaster for installation on your present reel, give the complete model number and serial number of your reel and the complete part number of the Guidemaster.

Circuit breaker must be used with all DC electric motors.

Note: This guidemaster can be used with reels up to a maximum drum width or B dimension of 22". Operates with up to a 2.16" OD hose.

FH-3 Roller and Spool Assembly

Not recommended for hoses larger than 1-1/2" ID

Speeds handling and reduces hose wear. Buffed stainless steel rollers resist corrosion, pitting and abrasion. Polished, chrome-plated spools and blocks add lasting beauty to your equipment. Delrin bearing surfaces assure quiet operation and minimum wear.

Assembly can be factory-installed, when specified, or ordered for field installation on reels or other equipment.

To Order: For factory installation, specify FH-3 Assembly and indicate position on reel. As an accessory, specify FH-3 Assembly and give length of roller (Dimension Z) and distance between mounting holes (Dimension X). Mounting brackets are available.

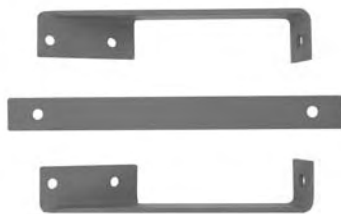
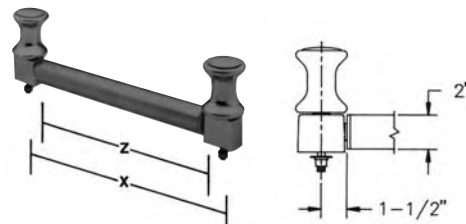
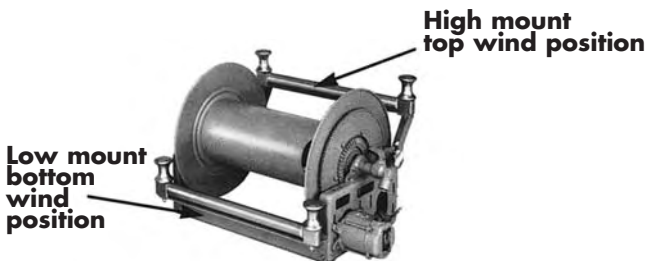

FH-3 Top Wind Mounting Brackets



FH-3 Bottom Wind Mounting Brackets

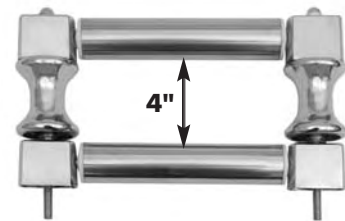

FH-3 Double Captive Roller Assembly

HOW TO ORDER ACCESORIES

Hannay Reels Accessories Order Form.

To order any of the accessories shown in this catalog, please provide the following information to your Hannay Reel Dealer.

1. Who are the accessories for?

Company _____	Street Address _____
Division _____	City _____ State _____ Zip _____ Country _____
Contact _____	(_____) / _____ / _____ Telephone _____ Fax _____ Date _____

2. What accessories are needed?

Item Name _____	Item Name _____
Part # _____	Part # _____
Page # _____	Page # _____
Reel model _____	Reel model _____
Reel serial # _____	Reel serial # _____
Item Name _____	Item Name _____
Part # _____	Part # _____
Page # _____	Page # _____
Reel model _____	Reel model _____
Reel serial # _____	Reel serial # _____
Item Name _____	Item Name _____
Part # _____	Part # _____
Page # _____	Page # _____
Reel model _____	Reel model _____
Reel serial # _____	Reel serial # _____

3. What are the specifications?

Please note: Provide any specifications called for in accessory description.

_____	_____
_____	_____
_____	_____
_____	_____

HANNAY REEL POLICIES

Our Guarantee and Service Policy

Equipment manufactured by Hannay Reels, Inc. is guaranteed for two years from date of shipment when installed according to our instructions, given proper care, and used for the purpose for which it is designed.

Equipment which proves to be defective upon our inspection will be replaced free of charge, including freight to the customer. Our responsibility ceases upon delivery to any common carrier and we do not, unless previously instructed, insure shipments beyond point of delivery to such carrier. No material will be accepted for return without a return goods authorization. No allowance will be made for labor charges incurred in making exchanges, replacements or repairs.

Components (including hose and cable) which are manufactured by other vendors will be subject to the warranty terms of their own manufacturers. Also excluded from the general guarantee are normal wear items (including seals, motor brushes, and paint finish).

We reserve the right to modify or alter materials, dimensions, design and construction when necessary to improve the performance of the reel and/or accessories, or to meet delivery requirements.

Failure to use a properly sized circuit breaker with any electric rewind motor will void warranty on motor.

Failure to use a flexible connector with any live hose reel will void warranty on swivel joint.

We expressly disclaim any liability for damage or injuries resulting from the use, operation, service, maintenance or failure of equipment.

Paint Notice

To meet the requirements and performance of vehicle and OEM apparatus paints we recommend our reels be painted with the same or equal paint as used on the specific apparatus the reel is being mounted on.

Hannay Reels will supply any model or custom reel or part with an automotive primer or rust preventative oil finish upon request, allowing application of final coating at your facility. Or at an additional cost Hannay can prime/pre-paint all material before final assembly.

In today's regulatory environment this would be the most cost-effective way to meet your finishing standards.

Consult factory for other optional finishes.

Standard finish is oven cured enamel. High performance finishes for demanding and corrosive environments are available at an additional cost. Consult factory for specific requirements.

Return Goods Policy

All Hannay Reels are built to order. The parts and components are ordered or placed into production as soon as the order is written.

In order to keep the number of returned goods at a minimum, we ask you use the Hannay Reels Order Worksheet and /or Accessories Order Form when specifying reels with us. These forms can be found on pages 8 and 16 of this catalog.

Be sure to include any size and /or weight limitations for your installation.

*In the event that an item does need to be returned for credit, repair or replacement, prior approval **must** be obtained from Hannay Reels, Inc. Upon your request, we will fax a Return Goods Authorization form. A signed copy of this form **must** accompany the material when returned to us.*

*All material must be returned prepaid, unless otherwise noted on our Return Goods Authorization. **No** return will be accepted that has been damaged due to improper return packaging, tampered with or altered from its original condition. **Equipment specially built to customer specifications and requirements is not subject to cancellation or returnable for credit under any conditions.***

*Our restocking and handling fee is a **MINIMUM** of 25% for standard catalog reels and parts.*

No material will be accepted for credit when returned without permission. Orders for equipment incorporating variations from catalog listed items are special and are not subject to return.

No allowance will be made for labor or mileage charges incurred in making exchanges, replacements, or repairs.

Domestic Inside Sales Dept.



Keith Hvizdak
Ext. #262



Noel Withjack
Ext. #295



Kim Winnie
Ext. #286



Rob Motschmann
Ext. #230



George Eignor
Ext. #240



Tim Healey
Ext. #210



Darren Bassler
Ext. #207



Tim Preston
Ext. #211



Lance Boehlke
Ext. #208

International Sales Department



Scott Hannay
Ext. #249



Carol Clarke
Ext. #241

Sales Manager



Dave Guilzon
Ext. #244

Manufacturing/ Production



Mike Ferguson
Ext. #234

To order your reels, use the convenient worksheet on page 8. Accessories for new or existing reels can be ordered using the worksheet on page 16. If you need assistance in determining the right reel for the job, don't hesitate to ask your dealer or to call one of our inside sales group.



Family owned and operated since 1933, Hannay Reels is the world leader in both OEM and aftermarket applications. Hannay offers thousands of standard hose reel and cable reel models, as well as unmatched custom capabilities. We can easily and affordably customize a reel to meet your exact specifications – built to last, delivered fast. Additional catalogs are available through your local Hannay Reels dealer or online at www.hannay.com.



553 State Route 143 • Westerlo, New York 12193
Toll Free Phone: **877**-467-3357 • Toll Free Fax: 800-733-5464

E-mail: reels@hannay.com

Intl. Phone: 1-518-797-3791 • Intl. Fax: 1-518-797-3259

www.hannay.com



MADE IN U.S.A.